

CELESTIN

Parking LED Marker | Indoor | Outdoor



Bidirectional LED light made of high-strength cast aluminium and impact-resistant polycarbonate to withstand the passage of vehicles.

APPLICATIONS:

- Car park marking
- Footbridge beaoning
- Beaoning in an industrial environment

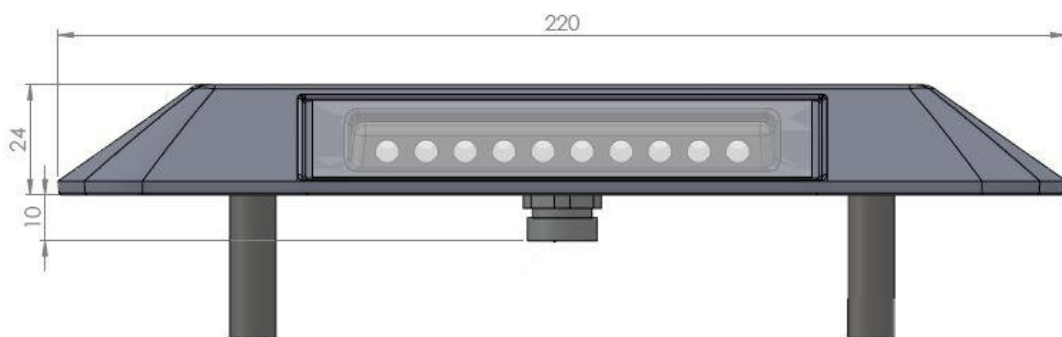

CELESTIN

Parking LED Marker | Indoor | Outdoor

Technical data	CELESTINS	CELEST
Dimensions	220*94mm	
Number of LEDs	2*24	2*12
Power	3W	
Body materials	Hardened aluminum foundry	
Glass materials	Polycarbonate 5mm	
LED Color	White Blue Red Green Amber	
Angle	15° 30° 50°	
Life span	50 000 hours L 70	
operating temperature	-30°C to +45°C	
Alimentation	24Vcc 48vcc	
Electrical class	Class III	
Connection	Cable CR1C1 2*1mm ² L=0.5m	
IK	IK10 - Rolling resistance light vehicle 20km/h	
IP	IP68	
Fixation	Shallow anti-pullout box	
Compliance	Certificated APAVE NF-EN 60598-2-22	
Glow wire test	850°C	
Warranty	5 years	
Place of manufacture	France	

Photometric data +/- 10%, the manufacturer reserves the right to modify the characteristics without prior notice.